

Solar-Powered Unmanned Aerial Vehicle

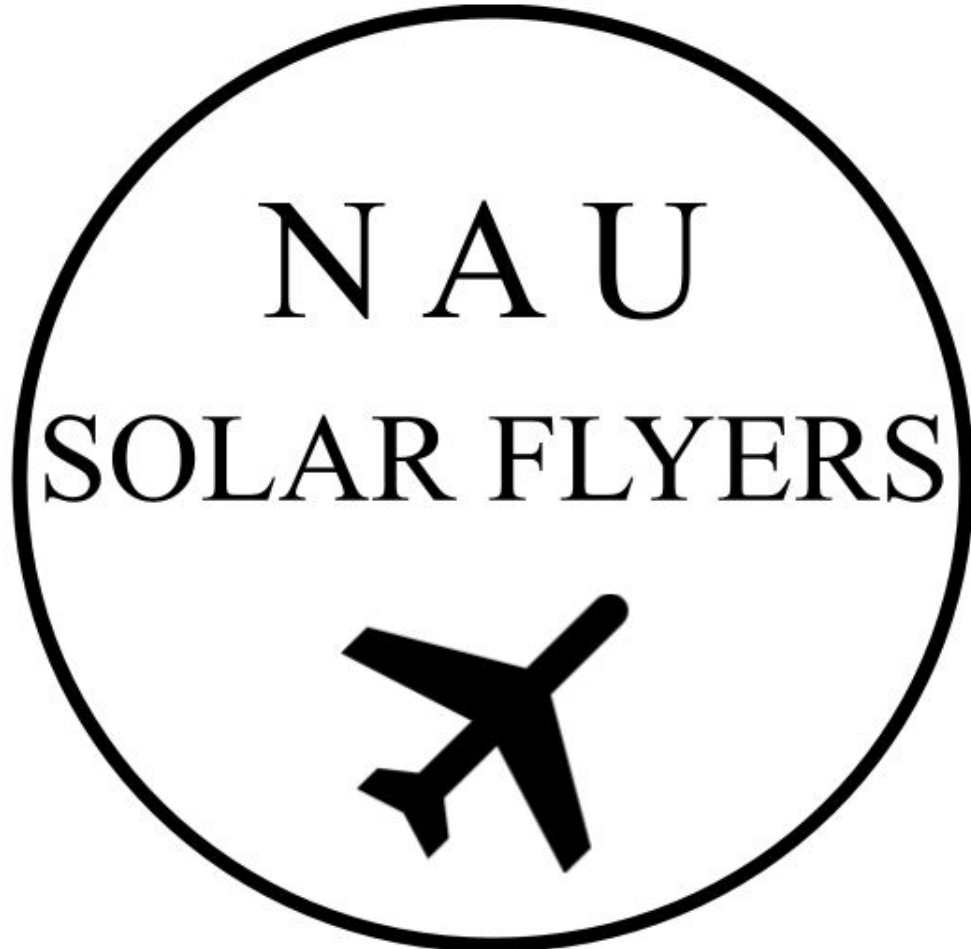

Update#3
11.18.22

Sultan Hazawbar & Gabriel Martin

Project Client: David Willy

Project Sponsor: Gore

Project Advisors: Venkata Yaramasu, Ph. D &
Alexander Dahlmann, GTA

Project Partners: ME 486C Team

EE (NAU) Solar Flyers

Gabriel Martin & Sultan Alhazawbar

Project start date: 1/10/2022

Milestone marker: 1

Scrolling increment: ##

Milestones

Milestone description	Assigned to	Progress	Start	Duration (# Days)	Finish
EE476C					
EE486C					
Recap Assessment	G.M	100%	8/29/2022	10	9/9/2022
1/3 Build Assessment	G.M & S.A	100%	9/9/2022	37	10/14/2022
Individual Contribution Assessment	G.M & S.A	100%	10/14/2022	16	10/28/2022
Website Check I	S.A	100%	10/14/2022	16	10/28/2022
2/3 Build Assessment	G.M & S.A	100%	10/14/2022	23	11/4/2022
Team Design Document II	G.M & S.A	100%	10/14/2022	30	11/11/2022
Website Check II	S.A	100%	10/28/2022	16	11/11/2022
Prototyping Phase A: Array Assembly	G.M	100%	11/11/2022	1	11/11/2022
Prototyping Phase B: Charge Controller Configuration / Connection	G.M & S.A	50%	11/18/2022	1	11/18/2022
Prototyping Phase C: Full Integration	G.M & S.A	0%	11/23/2022	1	11/23/2022
UGRAD Symposium	G.M & S.A	0%	12/2/2022	1	12/2/2022
3/3 Build Assessment	G.M & S.A	0%	11/4/2022	37	12/9/2022
Team Design Document III	G.M & S.A	0%	11/4/2022	37	12/9/2022
Website Check III	S.A	0%	11/11/2022	30	12/9/2022
Project Completion	G.M & S.A	0%	12/9/2022	1	12/9/2022

November December

1	2	3	4	5	6	7	8	9	10	11	12	13	14	15	16	17	18	19	20	21	22	23	24	25	26	27	28	29	30	1	2	3	4	5	6	7	8	9	10
T	W	T	F	S	S	M	T	W	T	F	S	S	M	T	W	T	F	S	S	M	T	W	T	F	S	S	M	T	W	T	F	S	S	M	T	W	T	F	S

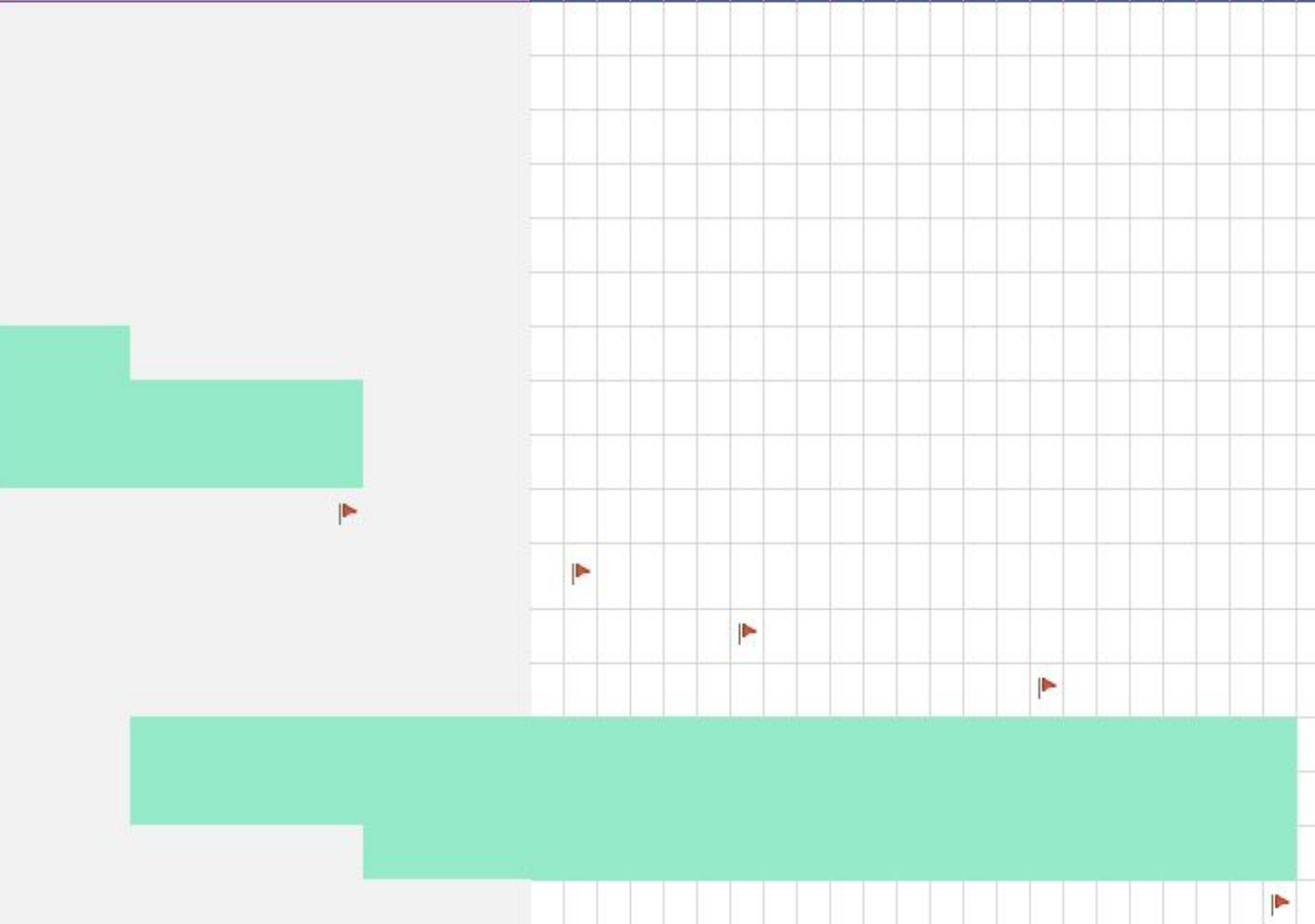

Overview

Goal: To construct a solar powered unmanned aerial vehicle (UAV) that will fly 1 1/2 times the duration that a sole onboard battery would fly it for.

Progress Update Since 11.4.22

- 1) Solar Cell Encapsulation
- 2) Array Assembly
- 3) Charge Controller Configuration
- 4) ME Progress
 - Successful Flight
 - Flight Controller
 - Final Iteration
- 5) Integration Approach
- 6) Next Steps

Solar UAV System Architecture

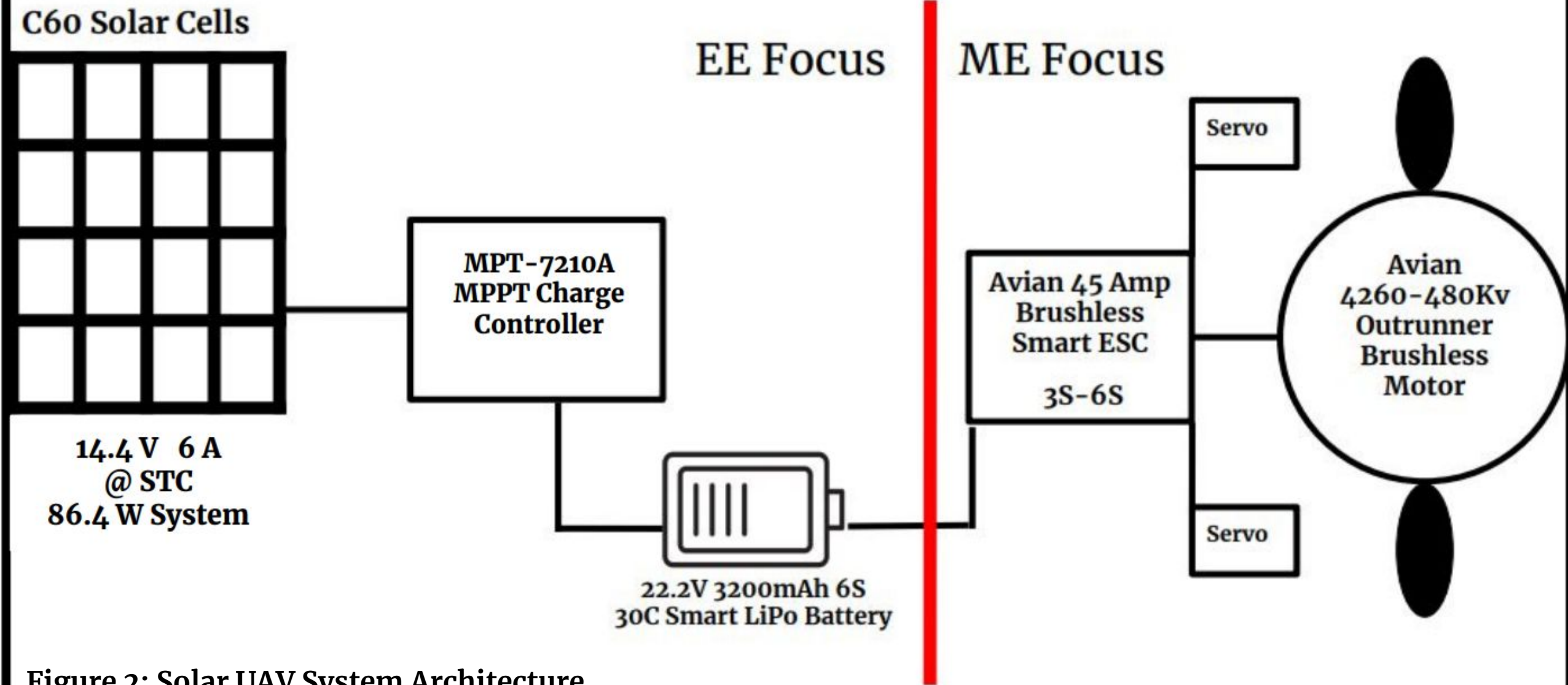

Figure 2: Solar UAV System Architecture

Solar Cell Encapsulation

Using lamination material for the protection of our solar array.



Figure 3: Solar Encapsulation Process (Backside)

- Self seal laminating
- No loss in efficiency with lamination film
- Frontside 100% covered
- Backside 90% covered with leads exposed
- Getting rid of air bubbles on front side

Array Assembly - Prototype A

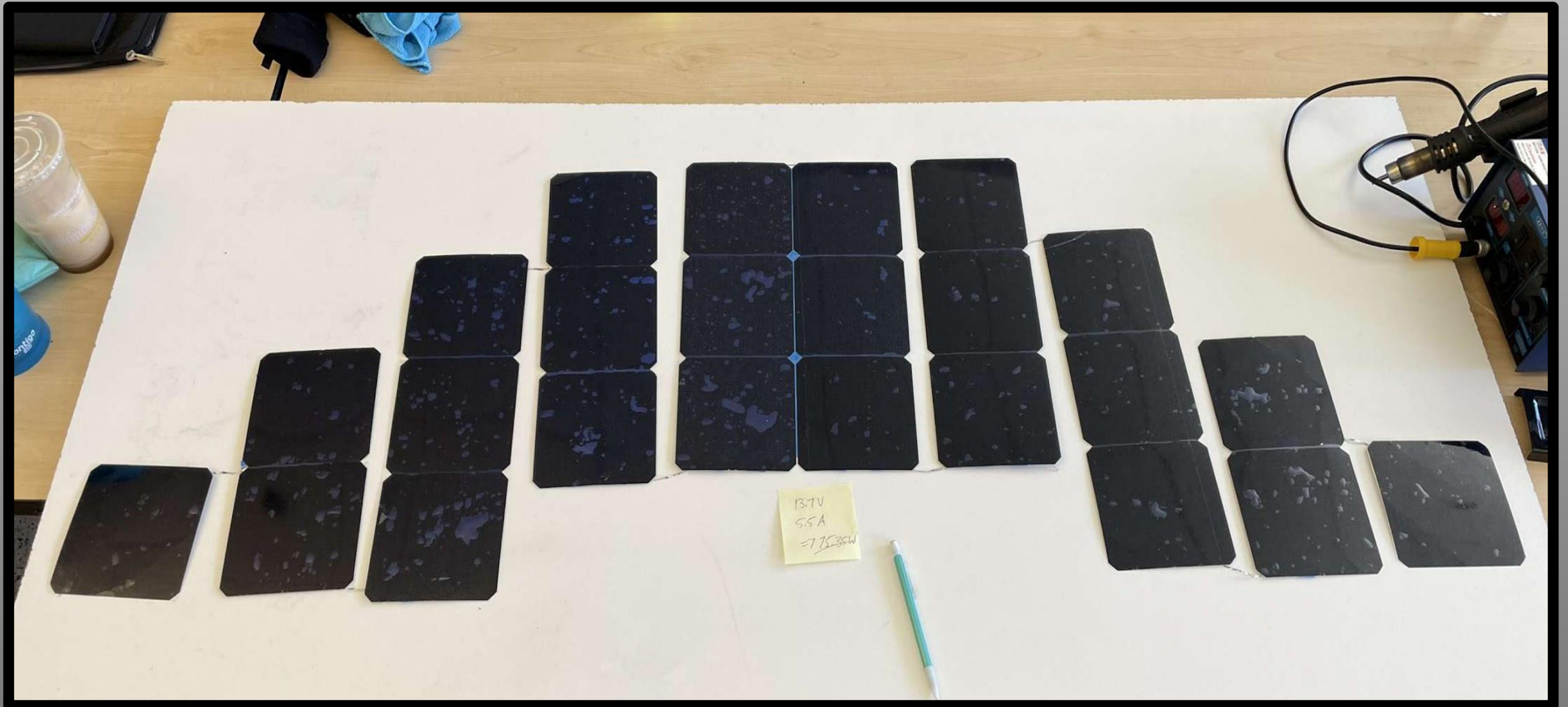
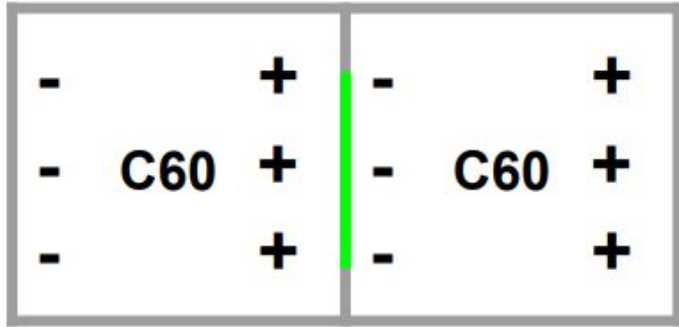



Figure 4: Full Solar Array (Frontside)



Dog Bone Connector .91g Each



 Fuselage Access Point

 Tapping Wire

Charge Controller Connections Are In Red Using 14 Gauge Wire

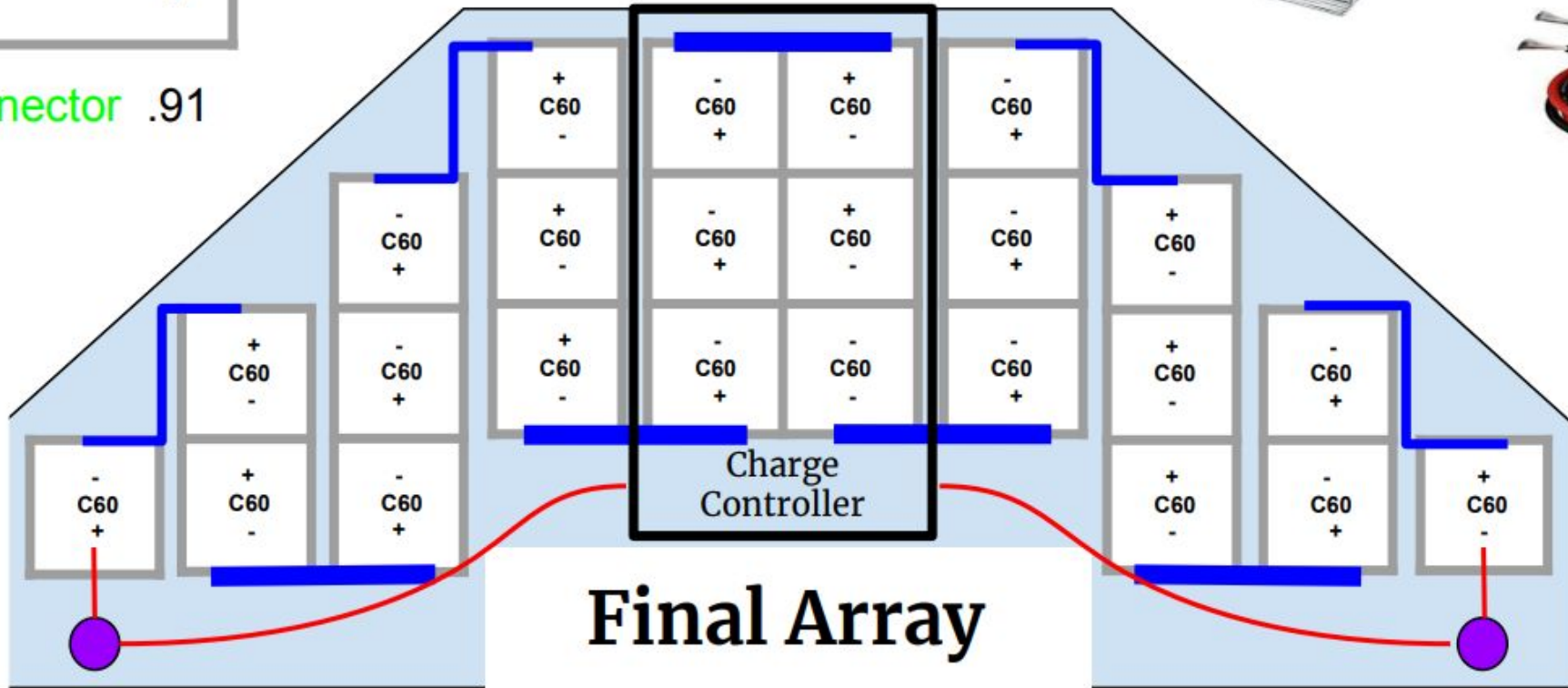

Figure 5: Schematic of Solar System on UAV

Array Assembly - Prototype A

<u>Initial Reads for PV Array for Solar UAV</u>	
- P _{pv}	71.96 W
- V _{pv}	12.58 V
- I _{pv}	5.72 A
- # of cells	24 Cells
- Weight	< 200 g
<u>Testing Conditions</u>	
- Time	12:30 PM on 11/13/22
- Temperature	43 ° F
- Array to the Sun's Orientation	Horizontal to Solar Noon

Table 1: PV Array Specifications

Charge Controller Configuration

<u>MPT - 7210A Charge Controller</u>	
● Input Voltage	DC 12 - 60V
● Input & Output Current	0 - 10 A Adjustable
● Output Power	20 - 600W
● Working Modes	MPPT and DC-DC Boost
● Item Size(approx)	131 * 96 * 54 mm
● Tracking Efficiency	98%
● Output Voltage	DC 15-90V Adjustable
● Initial Weight / Modified Weight	440g / 142g

Table 2: MPT-7210A Specifications

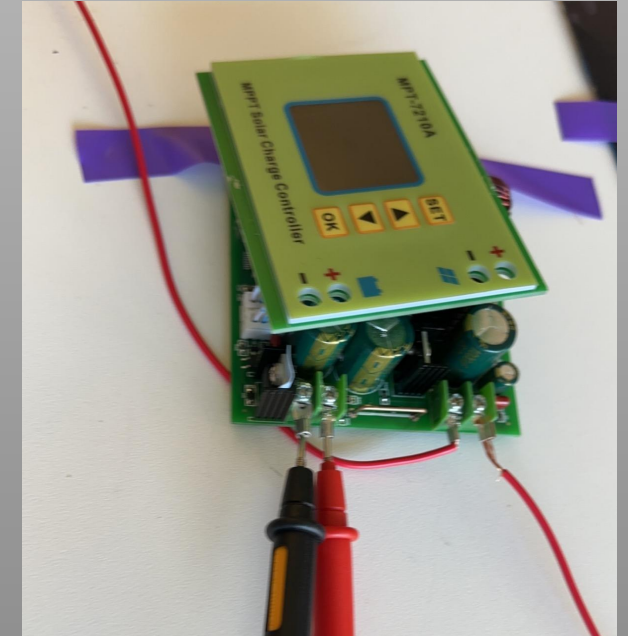

Figure 6: Unshelled Charge Controller

- 1) **Weight Adjustment:** Managed to shave the weight down to 142 g.
- 2) **Wiring:** 14 AWG wire from the array to the corresponding inserts by crimping the connectors onto the wire
- 3) **Initial Reading:** The charge controller took our input of 12 V and 5 1/2 Amps, and output 30V and 5 Amps to the voltmeter and the charge controller's screen, demonstrating its MPPT/Boost functionality.

Charge Controller Configuration

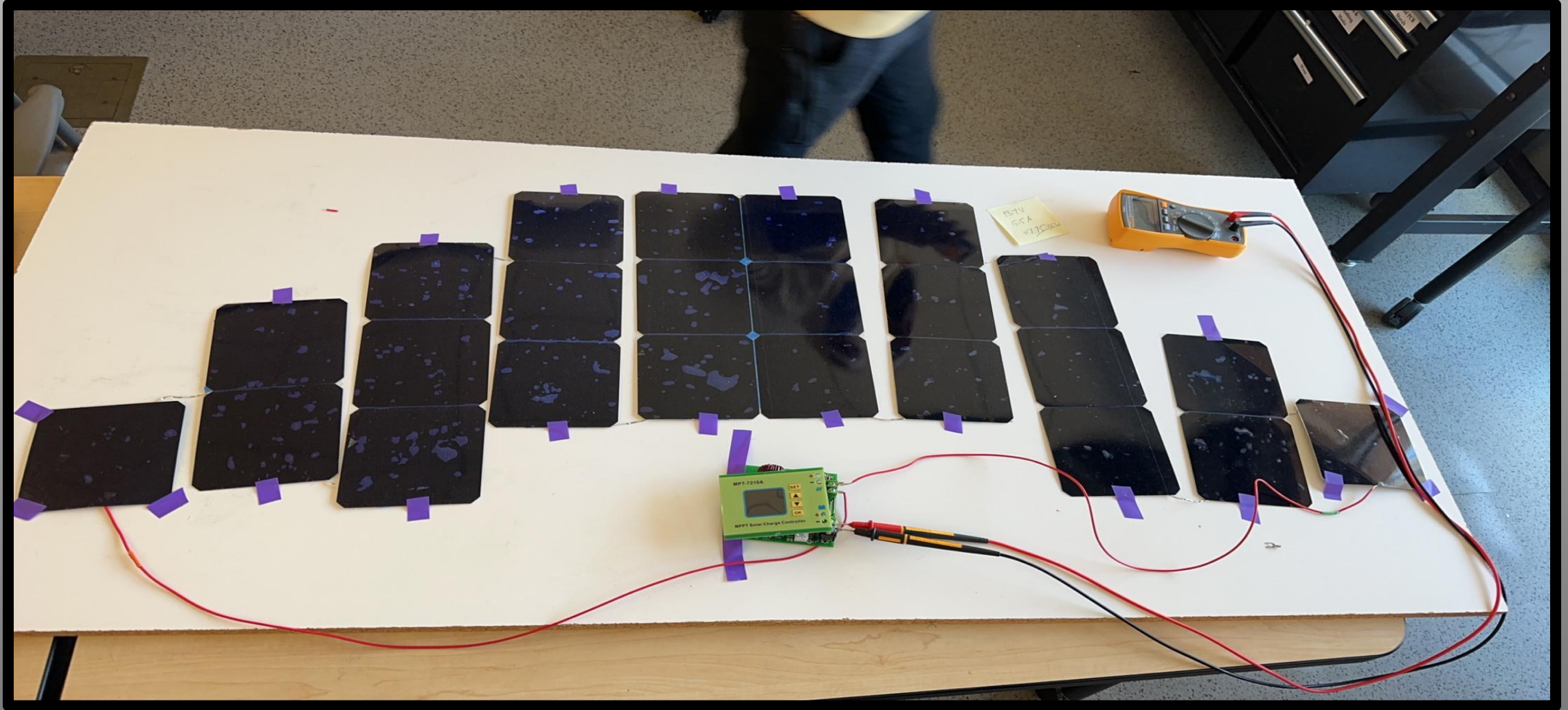

Figure 7: Solar System Connected to Charge Controller & Voltage Meter

ME Progress - Successful Flight



ME Progress - Flight Controller

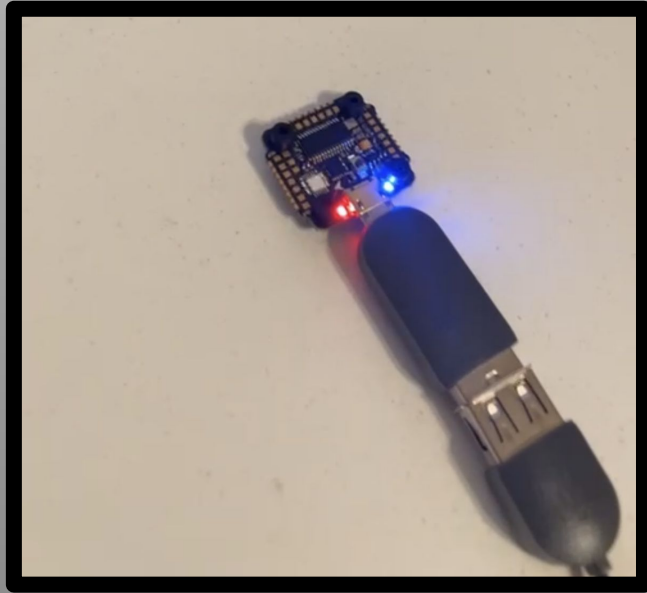

Figure 8: GPS for Flight Controller

Preset & Automated Flight

Real Time Tracking

GPS Navigation

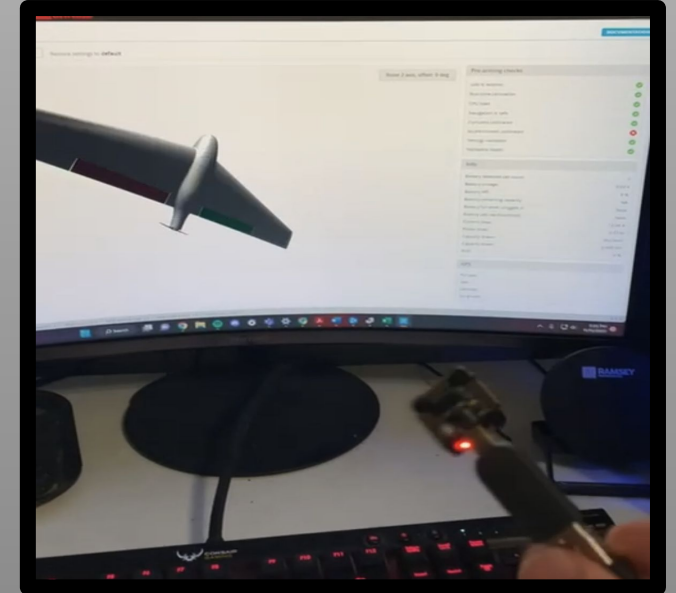

Figure 9: INAV Software for Flight Controller

Final Iteration of the Solar UAV

The 3rd iteration of the UAV has set the final conditions for our system:

- Back down to 24 cells
- New output power from array @ STC is around 86.4W
- Longer strips of tabbing wire because our cells will be spread out, but there no loss in efficiency
- Charge controller seems is working and is a perfect fit for our system.

Next Steps

- 1) Integration of our battery w/ charge controller
- 2) Monitor a successful flight without solar to set marks
- 3) Panel installation & full integration of our system onto the UAV
- 4) Demonstration of the final product
- 5) Class deliverables and UGRAD syponism preparation

Questions ?

